

スピンドル穴  
SPINDLE THRU-HOLE

仕様 SPECIFICATIONS	
割出精度 INDEXING ACCURACY	20 sec以内
再現精度 REPEATABILITY	4 sec以内
テーブル最高回転速度 MAXIMUM ROTATION SPEED	16.6 min <sup>-1</sup> [モータ 3000 min <sup>-1</sup> ]
クランプトルク CLAMPING TORQUE	2600N·m [エアプレス 0.5MPa]
許容最大空圧力 MAXIMUM PNEUMATIC PRESS	0.6 MPa
許容積載質量 ALLOWABLE MASS OF WORKPIECE	横 350 kg 直 180 kg
許容積載ワーク径 ALLOWABLE WORKPIECE DIA.	φ320 mm
総減速比 TOTAL REDUCTION RATIO	1/180
製品質量 MASS OF ROTARY TABLE	200 kg
軸動系モーメント慣性 (モータシャフトに換算) MACHINE INERTIA (REDUCED TO MOTOR SHAFT)	0.000348 kgm <sup>2</sup> (0.003558 kgf·cm·s <sup>2</sup> )

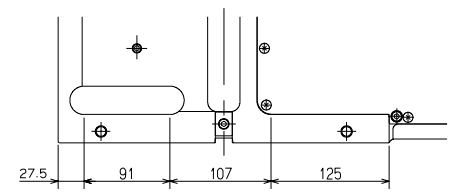

クランプ器具  
CLAMPING PARTS  
付属品 4組  
4 SETS

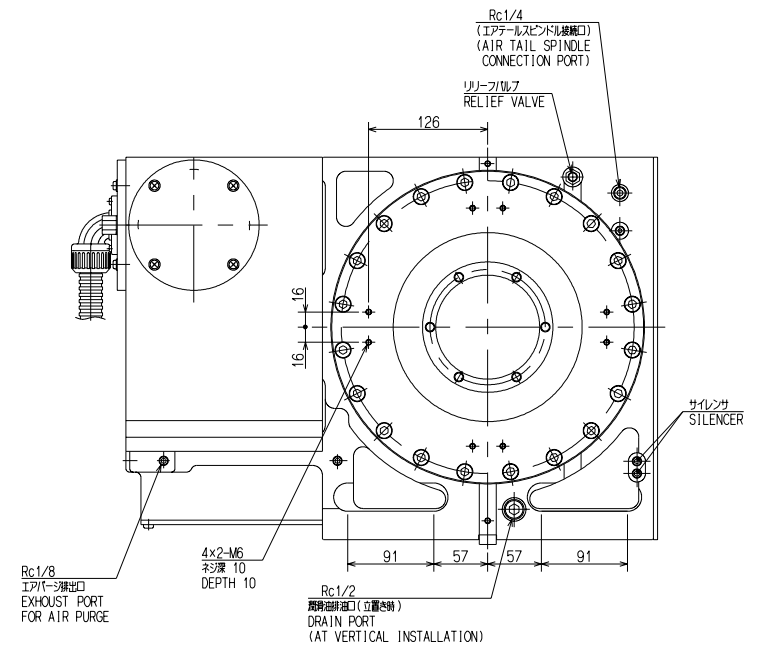
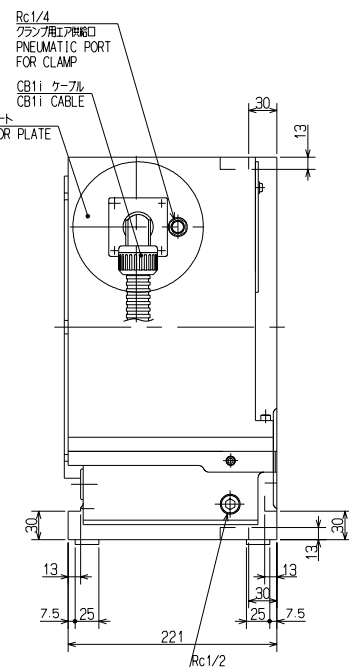
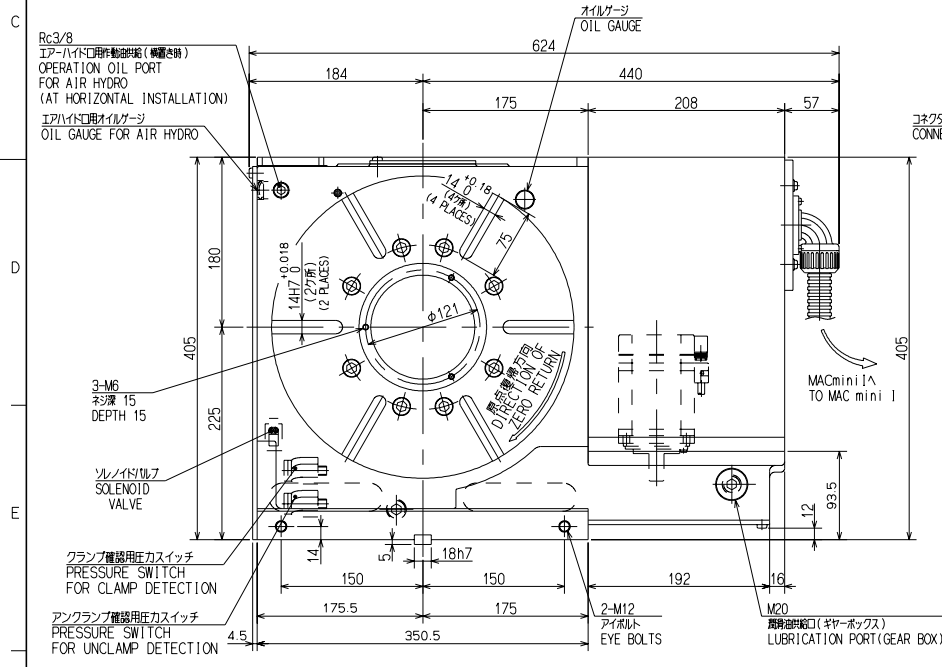
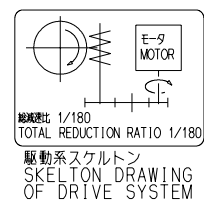
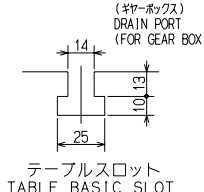

CAREER			SCALE	TYPE	TRX320B20	WEIGHT	k.g
MANAGER	CHIEF	DRAWN BY	1:4	NC	TRX320B20	NC ROTARY TABLE	
			3RD ANGLE	NAME	TRX320B20 ガイウェイ OUTSIDE VIEW		
KITAGAWA IRON WORKS CO.,LTD.			DATE	DRW NO.	61E 24 4506	2	